

RESISTIVE HIGH VOLTAGE DIVIDER FOR FAST RISE TIME SIGNALS

Gustavo G. Vasques, Marcelo A.H. Mello, Milton E. Kayama, Diego G.A. Reis and André B. Laraia
Universidade Estadual Paulista- Faculdade de Engenharia do Campus de Guaratinguetá

1. Introduction

High voltage techniques are frequently used to generate non-thermal plasmas in atmospheric pressure discharge and in several methods of material treatment with plasmas. To measure this high voltages the most usual method is by resistive voltage divider, an arrangements in series of resistances. This method is quite limited for fast rising signals. The correct response of the divider is provided by a capacitive element introduced in the circuit [1,2]. The probe voltage made with an arrangement of resistive voltage divider and a electrolytic solution with a electrolyte was assembled and characterized to achieve a reliable long lifetime operation.

2. Experiment

The probe has two electrodes, the upper one connected to the measuring point and the bottom one used as base and connected to the ground. Between these electrodes are the resistances of the divider and the electrolyte. The resistances are five film resistances in series inside an acrylic tube filled with transformer oil. One end of the set is connected to the upper electrode and the opposite end to the BNC. Through this connector the resistance is connected to a 50 Ω element where the voltage is measured. The electrolytes were CuSO_4 and MgSO_4 at various molar concentration. For characterization it was used sinusoidal signals from a signal generator HP model 3310B.

3. Results and discussions

Figure 2 shows the ratio between the output and input voltage with the frequency of the signal. It is also the attenuation factor of the voltage divider with 1000X nominal ratio. It is observed that the voltage ratio is affected by the concentration of the electrolyte. At high concentration the resistances at central axis is affected by the resistivity of the electrodes. This influence is reduced at low molar concentration and the attenuation becomes equal to the nominal value. That is similar to the response with distilled water, with flat voltage ratio until 1 MHz. Similar response is observed for both salts. Aging effect showed reliable attenuation for low concentration the electrolytes.

This work was supported by FAPESP, CNPq and CAPES.

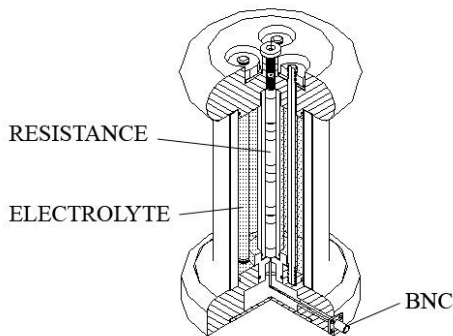

Fig.1 – Schematic view of the voltage divider.

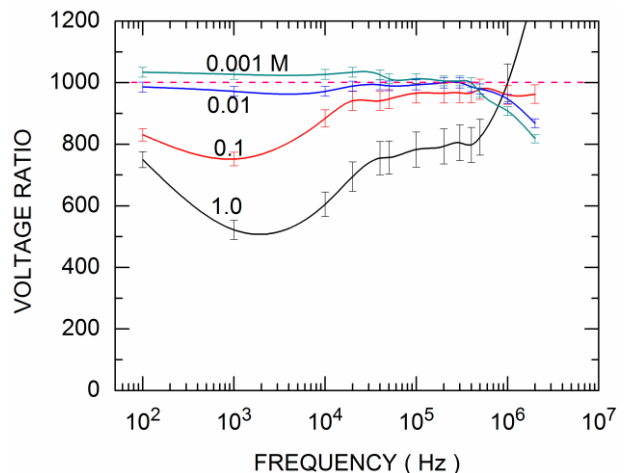

Fig.2 – Voltage ratio for 1000X voltage divider for each molar concentration of MgSO_4 .

References

- [1] Creed, F.C., Kawamura, T. and Newi, G., Step Response of Measuring Systems for High Impulse Voltages, IEEE. Trans. Power Apparatus and Systems, vol. PAS-86(11), 1408, 1967; doi: 10.1109/TPAS.1967.291819
- [2] Willis, W.L., Lecture 10: Measurement Techniques, Los Alamos Scientific Laboratory, Report LAUR 80-2272, 1980.